



DOSCO OVERSEAS ENGINEERING LIMITED

Mk 4

HEAVY DUTY ROADHEADER



Mk 4 Roadheader

Mk 4 OUTLINE DATA	TYPICAL SPECIFICATION
Machine Weight (Base Machine)	96 tonnes
Total Power (Standard Machine)	From 407 kW
Power on Cutting Boom (Standard Machine)	Up to 250 kW
Hydraulic System Working Pressure	140 bar
Tracking Speeds – Sumping/Flitting	0.034/0.15 m/sec
Ground Pressure	1.60 kg/cm²

The Mk 4 roadheader is designed to give greater strength and power to the well proven cutting boom principle.

A powerful boom assembly with high arcing and lifting forces enables the machine to cut harder stratas in roadways up to 5300 mm high.

The excavated material is loaded by twin gathering arms or spinners onto a centrally mounted twin strand scraper conveyor powered by an electric motor. The gathering apron has the facility to be sumped forward 400 mm to improve gathering on down gradients.



**YOUR PARTNER
FOR ALL ROUND QUALITY AND RELIABILITY**



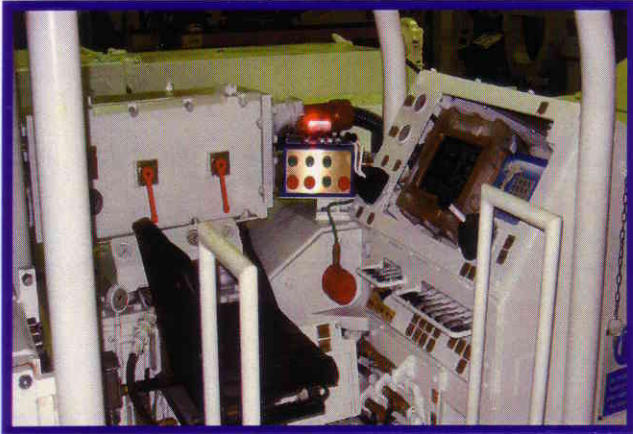

Mk 4 operator's position

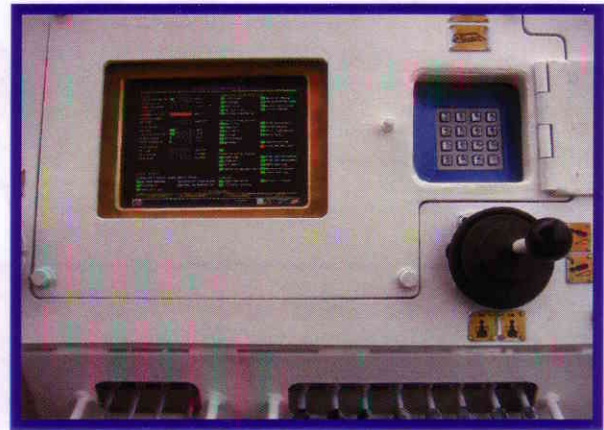

PLC display and keypad

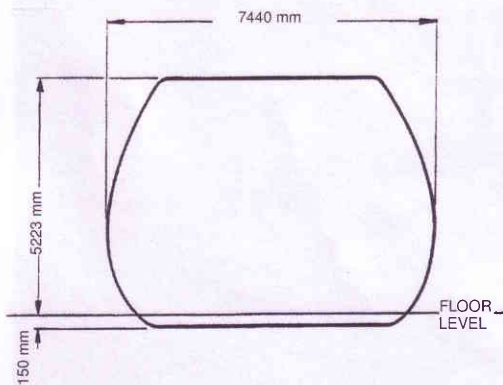

Mk 4 excavation profile

OPTIONS include:

- **Raised Pressure Water Systems** – improved dust suppression, reduced risk of incendive sparking, increased cutter tool life.
- **Operators Canopy** – custom designed to suit individual application requirements.
- **Gas Detection System**
- **Diagnostic Control System** – monitors state of selected electrical and water functions.
- **Coanda Air Curtain** – retains dust forward of the operators position for extraction by mine ventilation system
- **Profile Indication System and Data Logging**

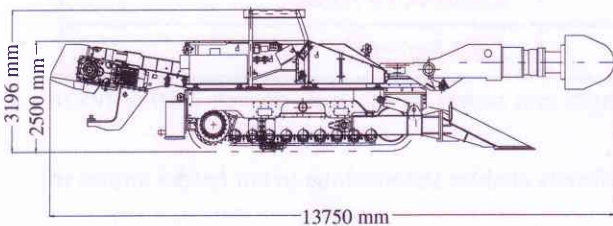
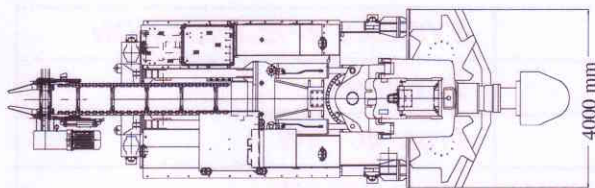

Document Issue 1 Revision 0 20/01/06

PLEASE NOTE - Data is intended as a guide only as machines may vary according to specification requirements.



DOSCO OVERSEAS ENGINEERING LTD

Ollerton Road, Tuxford, Newark Nottinghamshire, NG22 0PQ England
 Telephone: + 44 (0) 1777 870621 Facsimile: + 44 (0) 1777 871580
 E-mail: info@dosco.co.uk Website: www.dosco.co.uk



A member of the Amco Corporation Plc group of companies.

